

Lyde Score 1: Under the I405 bridge at Johnson.

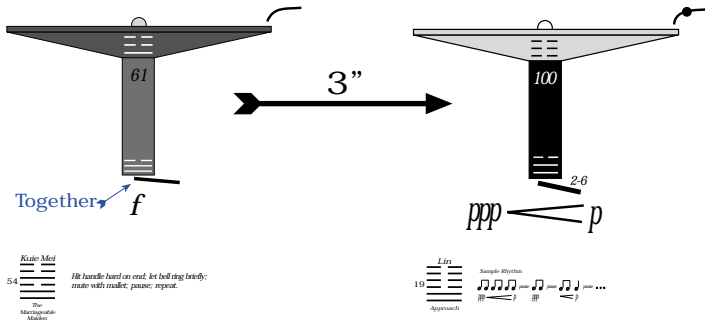

Lyde Score 2: PNCA, the corner of Johnson and NW 13th.

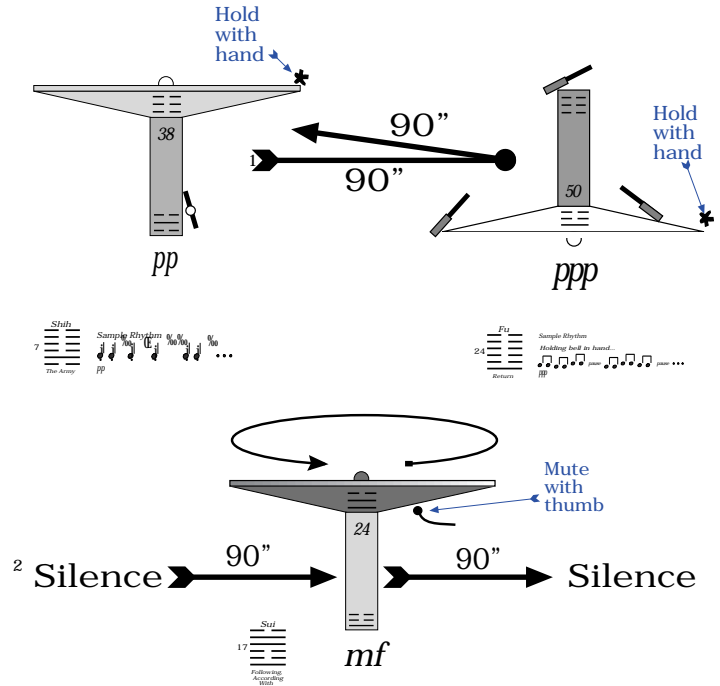

Lyde Score 4: Glisan and NW 13th.

Lyde Score 3: Hoyt and NW 12th.

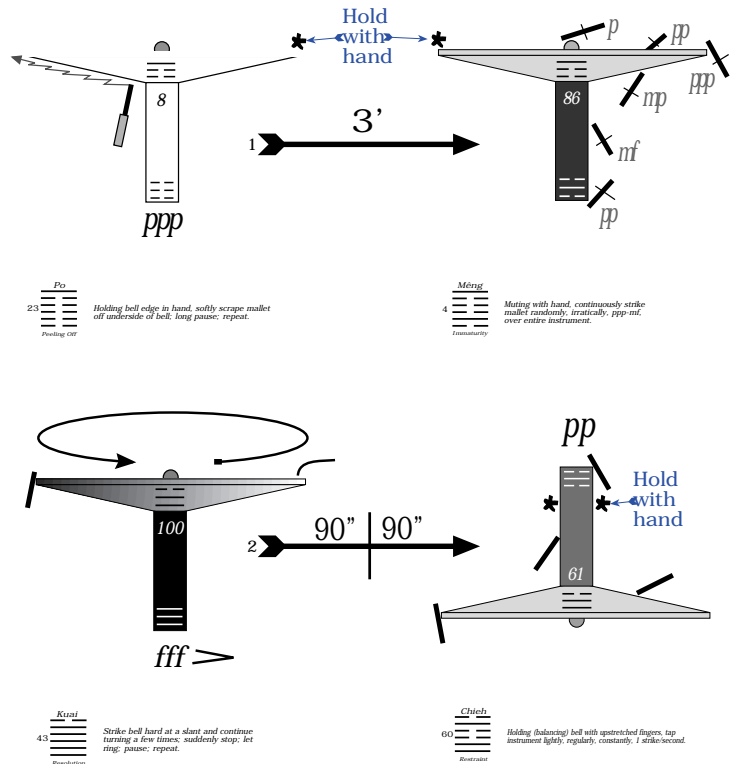
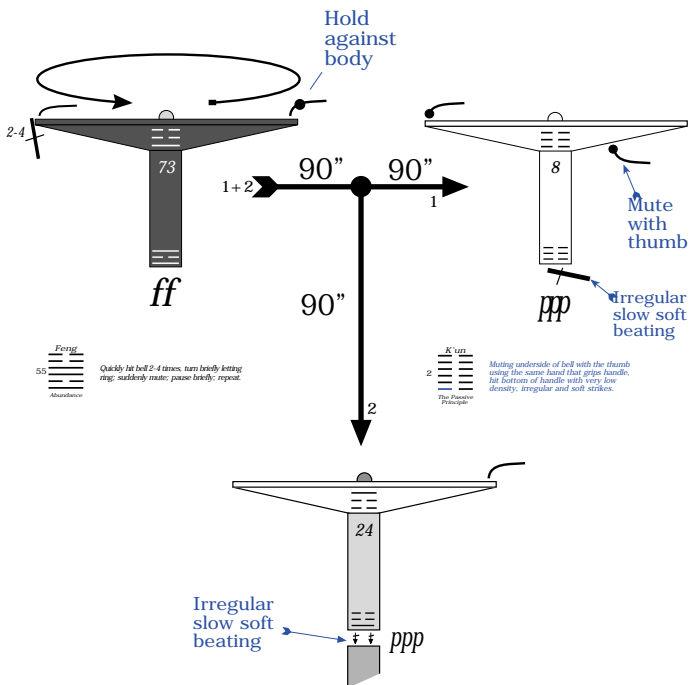

Lyde Score 5: Glisan and NW 12th.

61 *pp*
Hold with hand

73 *mf* *ppp*
Fast eight notes gradually getting softer
Hold with hand

86 *pp* *f*
Fast
Hold with hand

Chieh 60
Holding (balancing) bell with upstretched fingers, tap instrument lightly, regularly, constantly, 1 strike/second.

Chih Chih 63
After completion

Lyde Score 6: Glisan and NW 11th.

61 *f*
Together

86 *fff*
Hit bell hard and regular

100 *ppp* *p*
2-6

38 *f* *Together*
Bend to ground and drop lightly

Kuan Mei 54
Hit handle hard on end, let bell ring briefly; mute with mallet; pause; repeat.

Hsieh 40
Holding with both hands, drop bell short distance to surface; pause; pause; repeat irregularly.

Ting 50
Hit bell hard with uncovered edge of mallet; let ring; when silent, repeat.

Liu 10
Simple Rhythm

Lyde Score 7: Glisan and NW 9th.

100 *ppp* *f*
Slow->fast->slow, mute & repeat

50 *p*
Hold with hand

86 *mf*

61 *pp*

Hsiao Ch'u 9
Quickly crescendo from silence to a loud volume and then gradually decrescendo; mute with mallet at end; repeat.

Chi Yeh 15
5-7 quick soft clicks down handle; pause; repeat.

Ku 18
Holding handle at end (bell dangling below), drop uncovered end of mallet on bell; pause briefly after bell stops ringing; repeat.

Chieh 60
Holding (balancing) bell with upstretched fingers, tap instrument lightly, regularly, constantly, 1 strike/second.

Lyde Score 8: Davis and NW 9th.

86 *mp* *mf*
Mute with thumb
Wave bell

50 *p*

73 *mf* *ppp*
Fast eight notes gradually getting softer

Ching 48
A Word

Chi Yeh 15
5-7 quick soft clicks down handle; pause; repeat.

Chih Chih 63
After completion